

There is no need to purge a beer line that is protected with a FOB Detector when tapping a new keg.

TECHNICAL DRAWING

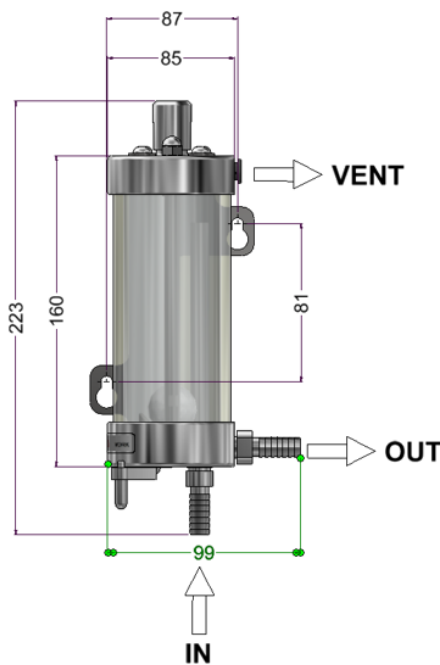

The **Foam on Beer (FOB) detector** will immediately shut down the beer flow when a keg empties. This eliminates foam and wasted beer after a keg has “blown” because the beer lines stay full of beer at all times. Pint after pint, our FOB Detector has proven to be the most dependable and competitively priced stainless FOB on the market.

Features:

- High quality, high volume acrylic bowl.
- Reduces beer wastage during keg changeover.
- Freestanding or compatible with Lancer beer manifolds.
- Prevents buildup of CO2/N2 in beer lines, inhibiting the growth of bacteria.
- Manufactured from food grade stainless.
- Self-sealing vent valve.
- Supplied standard with 10mm barb fittings
- Multiple Inlet and outlet options.
- No brass or chrome to contaminate beer.
- Easy do it yourself installation and maintenance.

Reversible mounting bracket.



Fob Detector

Multiple Inlet and Outlet Options

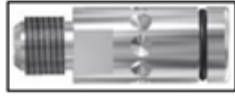

Fatlock Adaptor
Part #79646775



12mm Barb fitting
Part #79646785

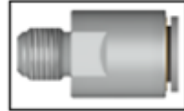

1/2 Inch John Guest
Part #79001131

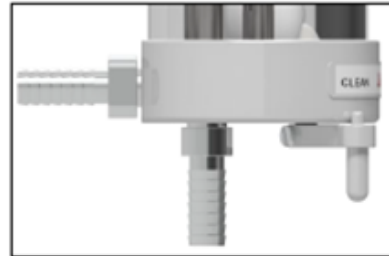

10mm Barb Fittings (Standard)

FOB Seal Kit Part No. 41000018

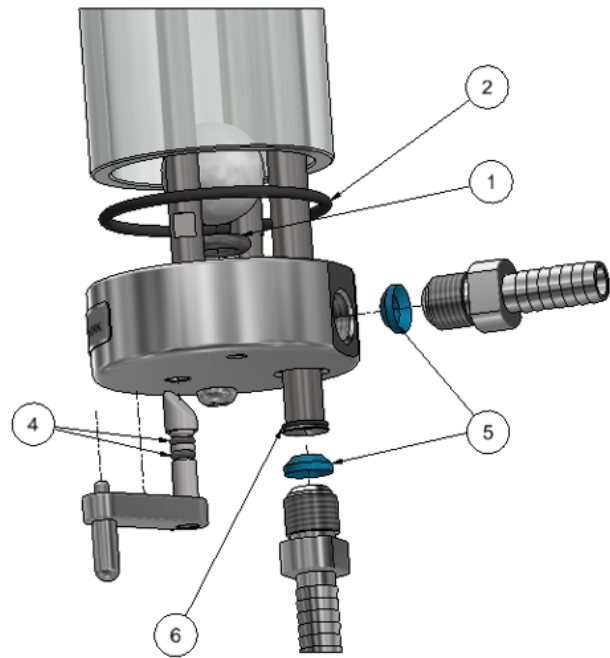
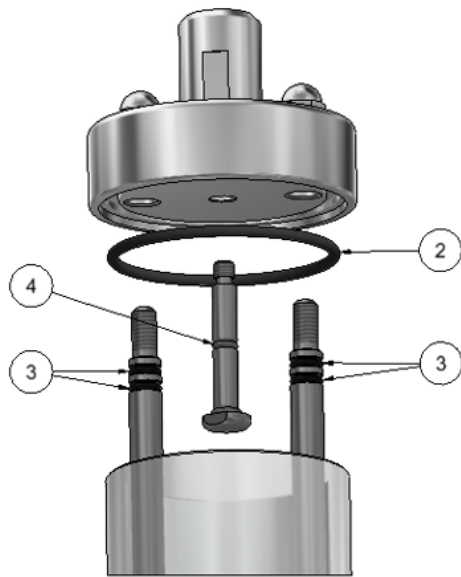

PRODUCT RANGE

Item	Part No.	Description
1	79001129	ORING BS204 NITRILE 70 DURO
2	79000181	ORING BS137
3	79700862	ORING BS008 NBR DURO 70
4	79646657	ORING BS005
5	79001147	SEAL ATLAS FOB BLUE LDPE
6	79000174	ORING BS009 NITRILE DURO 70